

## **QFP-LW31HG-A0DC**

100Gbps QSFP28 Transceiver, Single Mode, 100km Reach

### **FEATURES**

- Support line rates from 103.125 Gb/s;
  - Lane bit rate 25.78 Gb/s 100GE
  - Up to 100km transmission with KR4-FEC.
  - LAN WDM EML laser and PIN receiver with SOA;
  - Support Multi-Pin function with IntL/RxLOSL and
  - High speed I/O electrical interface (CAUI-4);
  - I2C interface with integrated Digital Diagnostic monitoring;
  - QSFP28 MSA package with duplex LC connector;
  - Single +3.3V power supply
- Power dissipation
- Commercial: < 5.5W
- Complies with EU Directive 2015/863/EU

### **APPLICATIONS**

- 100GBASE-ZR4 Ethernet
- 100G Datacom& Telecom connections

### **Description**

QFP-LW31HG-A0DC is designed for 100km optical communication applications. Optical transceiver integrates the transmit and receive path onto one module. On the transmit side, four lanes of serial data streams are recovered, retimed, and passed on to four laser drivers, which control four electric-absorption modulated lasers (Lan-WDM) with 1296, 1300, 1305, and 1309 nm center wavelengths. The optical signals are then multiplexed into a single-mode fiber through an

industry-standard LC connector. On the receive side, four lanes of optical data streams are optically DE multiplexed by an integrated optical DE multiplexer. After the optical signal is amplified by SOA, DEMUX separates four channels which are recovered by PIN photodetector and cross-impedance amplifier, retimed, and passed on to an output driver. This module features a hot-pluggable electrical interface, low power consumption, and 2-wire serial interface.

## Recommend Operating Conditions

Parameter	Symbol	Min	Typ	Max	Unit	Notes
Operating Case Temperature	Top	0		+70	°C	1
Power Supply Voltage	VCC	3.14	3.3	3.47	V	
Maximum Power Dissipation	P <sub>D</sub>			5.5	W	1
Lane Bit Rate			25.78125		Gb/s	
Transmission Distance	TD			100	km	
Coupled fiber	Single mode fiber					2

Notes:

1. The product name is QFP-LW31HG-A0DC.
2. Optical fiber use 9/125um SMF.

## Absolute Maximum Ratings

It has to be noted that the operation in excess of any individual absolute maximum ratings might cause permanent damage to this module.

Parameter	Symbol	Min	Max	Unit	Notes
Storage Temperature	TS	-40	85	degC	
Operating Case Temperature	TOP	0	70	degC	
Power Supply Voltage	VCC	-0.5	3.6	V	
Damage Threshold, each Lane	THd	5.5		dBm	
RelativeHumidity (non-condensation)	RH	0 to 85% non-condensing		%	

The following characteristics are defined over the Recommended Operating Environment unless otherwise specified.

## Optical Characteristics

Parameter	Symbol	Min	Typ	Max	Unit	Note
<b>Transmitter</b>						
Signaling Speed per Lane			25.78125		Gbps	
Center Wavelength Lane 0	$\lambda_0$	1294.53	1295.56	1296.59	nm	
Center Wavelength Lane 1	$\lambda_1$	1299.02	1300.05	1301.09	nm	
Center Wavelength Lane 2	$\lambda_2$	1303.54	1304.58	1305.63	nm	
Center Wavelength Lane 3	$\lambda_3$	1308.09	1309.14	1310.19	nm	
Total Launch Power, 100GE	$P_T$	9		12.5	dBm	1
Average Launch Power per Lane,	$P_{avg}$	3		6.5	dBm	1
OMA, each Lane	$P_{OMA}$	4.2		7.7	dBm	1
Difference in launch power between any two lanes(Average and OMA) between any Two Lanes (OMA)	$P_{tx,diff}$			3	dB	
Average Output Power (Laser Turn off)	$P_{off}$			-30	dBm	
Side Mode Suppression Ratio	SMSR	30			dB	
Extinction Ratio, 100GE	ER	6			dB	
RIN20OMA	RIN			-130	dB/Hz	
Optical Return Loss Tolerance	TOL			20	dB	
Transmitter Reflectance	$R_T$			-12	dB	
Optical Eye Mask		{0.25,0.4, 0.45, 0.25, 0.28, 0.4}			%	2
<b>Receiver</b>						
Signaling rate, each lane			25.78125		Gbps	
Center Wavelength Lane 0	$\lambda_0$	1294.53	1295.56	1296.59	nm	
Center Wavelength Lane 1	$\lambda_1$	1299.02	1300.05	1301.09	nm	
Center Wavelength Lane 2	$\lambda_2$	1303.54	1304.58	1305.63	nm	
Center Wavelength Lane 3	$\lambda_3$	1308.09	1309.14	1310.19	nm	
Damage threshold , each lane	$P_{damage}$	5.5			dBm	
Receiver sensitivity Average, each lane	SEN			-30	dBm	3
Los Assert	LosA	-40			dBm	
Los De-assert	LosDA			-31	dBm	

### Notes:

1. The optical power is launched into SMF。
2. Measured with a PRBS  $2^{31}-1$  test pattern @25.78125, Hit ratio $\leq 5E-5$ 。
3. Measured with a PRBS  $2^{31}-1$  test pattern @25.78125 Gb/s, BER $\leq 5E-5$ 。

### Electrical Characteristics

The following electrical characteristics are defined over the Recommended Operating Environment unless otherwise specified.

Parameter	Test Point	Min	Typ	Max	Unit	Notes
<b>Transmitter (Module Input)</b>						
Data Rate, each lane			25.78125		Gbps	
Differential Voltage pk-pk	Vpp			900	Mv	1
Common Mode Voltage	Vcm	-350		2850	Mv	
Transition time	Trise/Tfall	10			ps	2
<b>Receiver (Module Output)</b>						
Data Rate, each lane					25.78125	
Common Mode Noise, RMS	Vrms			17.5	Mv	
Differential output voltage swing	Vout, pp			900	Mv	
Eye width	EW15	0.57			UI	
Eye height	EH15	228			mV	
Differential Termination Resistance Mismatch				10	%	1
Transition time	Trise/Tfall	12			ps	
Data Rate, each lane			25.78125		Gbps	
Common Mode Noise, RMS	Vrms			17.5	Mv	

Notes:

1. At 1 MHz.
2. 20%~80%.

### Digital Diagnostic Monitoring Specifications

Parameter	Unit	Specification
Temperature Monitor absolute error	°C	±3.0
Supply Voltage Monitor absolute error	%	± 5
I_bias Monitor absolute error	%	± 10
Received Power (Rx) Monitor absolute error	dB	± 3.0
Transmit Power (Tx) Monitor absolute error	dB	± 3.0

## QSFP28 Module EEPROM Information and Management

Digital diagnostics monitoring function is available on all QFP-LW31HG-A0DC module. A 2-wire serial interface provides user to contact with module.

The structure of the memory is shown in Figure 3. The memory space is arranged into a lower, single page, address space of 128 bytes and multiple upper address space pages. This structure permits timely access to addresses in the lower page, such as interrupt Flags and Monitors. Less time critical time entries, such as serial ID information and threshold settings, are available with the Page Select function.

The interface address used is A0xh and is mainly used for time critical data like interrupt handling in order to enable a one-time-read for all data related to an interrupt situation. After an interrupt, IntL, has-been asserted, the host can read out the flag field to determine the affected channel and type of flag. For detail EEPROM information, please refer to the related document of SFF-8636\_R2.10a.

**Table 1 - Digital Diagnostic Memory Map (Specific Data Field Descriptions)**

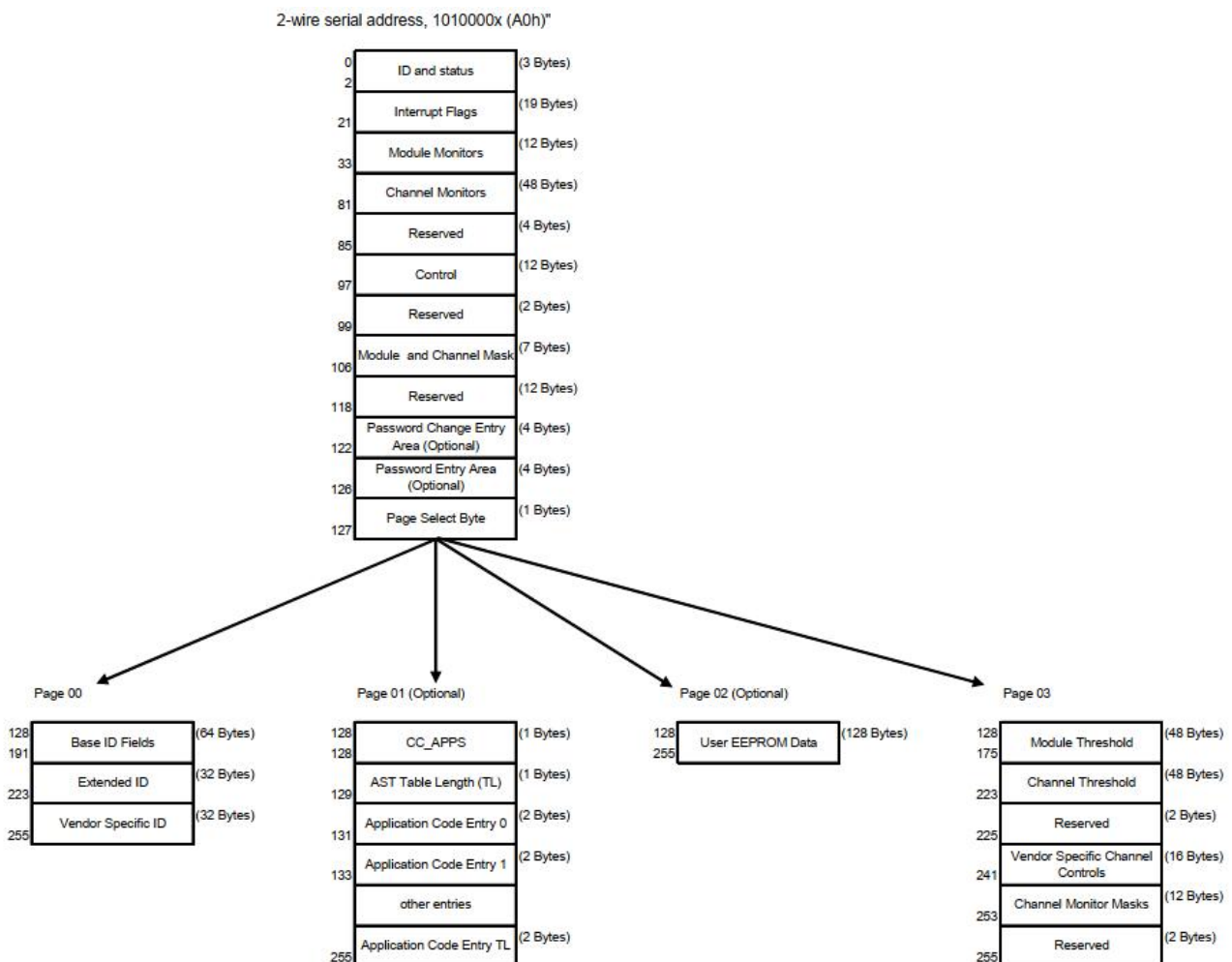
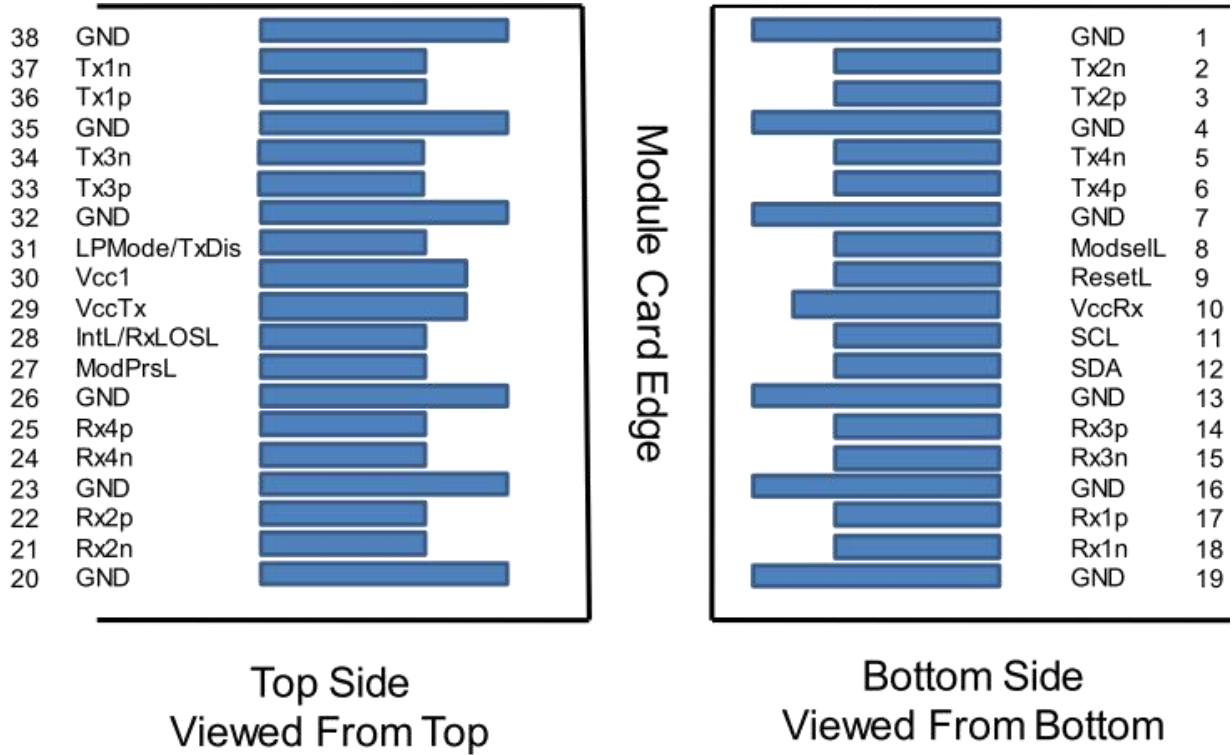

Table 2 - EEPROM Serial ID Memory Contents

Data Address (From)	(To)	Content	Type
<b>2-Wire SerialAddress 1010000x</b>			
<b>Lower Page 00h</b>			
0	2	ID and Status	Read-Only
3	21	Interrupt Flags (Clear on read)	Read-Only
22	33	Free Side Device Monitors	Read-Only
34	81	Channel Monitors	Read-Only
82	85	Reserved	Read-Only
86	99	Control	Read/Write
100	106	Free Side Interrupt Masks	Read/Write
107	110	Free Side Device Properties	Read-Only
111	112	Assigned to PCI Express	Read/Write
113	116	Free Side Device Properties	Read-Only
117	118	Reserved	Read/Write
119	122	Optional Password Change	Write-Only
123	126	Optional Password Entry	Write-Only
127	127	Page Select Byte	Read/Write
<b>Upper Page 00h</b>			
128	128	Identifier	Read-Only
129	191	Base ID Fields	Read-Only
192	223	Extended ID	Read-Only
224	255	Vendor Specific ID	Read-Only
<b>Page 01h (Optional)</b>			
128	255	Reserved (previously for SFF-8079 support)	Read-Only
<b>Page 02h (Optional)</b>			
128	255	User EEPROM Data	Read/Write
<b>Page 03h (Optional)</b>			
128	175	Free Side Device Thresholds	Read-Only
176	223	Channel Thresholds	Read-Only
224	229	TxE0, Rx Output and TC Support	Read-Only

### Pin Assignment and Description



PIN	Logic	Symbol	Description	Plug Seq.	Notes
1		GND	Ground	1	1
2	CML-I	Tx2n	Transmitter Inverted Data Input	3	
3	CML-I	Tx2p	Transmitter Non-Inverted Data output	3	
4		GND	Ground	1	1
5	CML-I	Tx4n	Transmitter Inverted Data Input	3	
6	CML-I	Tx4p	Transmitter Non-Inverted Data output	3	
7		GND	Ground	1	1
8	LVTLL-I	ModSelL	Module Select	3	
9	LVTLL-I	ResetL	Module Reset	3	
10		VccRx	+ 3.3V Power Supply Receiver	2	2
11	LVC MOS-I/O	SCL	2-Wire Serial Interface Clock	3	
12	LVC MOS-I/O	SDA	2-Wire Serial Interface Data	3	
13		GND	Ground	1	

14	CML-O	Rx3p	Receiver Non-Inverted Data Output	3	
15	CML-O	Rx3n	Receiver Inverted Data Output	3	
16		GND	Ground	1	1
17	CML-O	Rx1p	Receiver Non-Inverted Data Output	3	
18	CML-O	Rx1n	Receiver Inverted Data Output	3	
19		GND	Ground	1	1
20		GND	Ground	1	1
21	CML-O	Rx2n	Receiver Inverted Data Output	3	
22	CML-O	Rx2p	Receiver Non-Inverted Data Output	3	
23		GND	Ground	1	1
24	CML-O	Rx4n	Receiver Inverted Data Output	3	1
25	CML-O	Rx4p	Receiver Non-Inverted Data Output	3	
26		GND	Ground	1	1
27	LVTTL-O	ModPrsL	Module Present	3	
28	LVTTL-O	IntL/Rx_LOS	Interrupt/Rx_LOS	3	
29		VccTx	+3.3 V Power Supply transmitter	2	2
30		Vcc1	+3.3 V Power Supply	2	2
31	LVTTL-I	LPMODE/TxDIS	Low Power Mode/Tx_Disable	3	
32		GND	Ground	1	1
33	CML-I	Tx3p	Transmitter Non-Inverted Data Input	3	
34	CML-I	Tx3n	Transmitter Inverted Data Output	3	
35		GND	Ground	1	1
36	CML-I	Tx1p	Transmitter Non-Inverted Data Input	3	
37	CML-I	Tx1n	Transmitter Inverted Data Output	3	
38		GND	Ground	1	1

**Notes:**

1. GND is the symbol for signal and supply (power) common for the QSFP28 module. All are common within the QSFP28 module and all module voltages are referenced to this potential unless otherwise noted. Connect these directly to the host board signal-common ground plane.
2. Vcc Rx, Vcc1 and Vcc Tx are the receiver and transmitter power supplies and shall be applied concurrently. Requirements defined for the host side of the Host Edge Card Connector are listed in MSA. The connector pins are each rated for a maximum current of 1000 Ma.



## Mechanical Dimensions

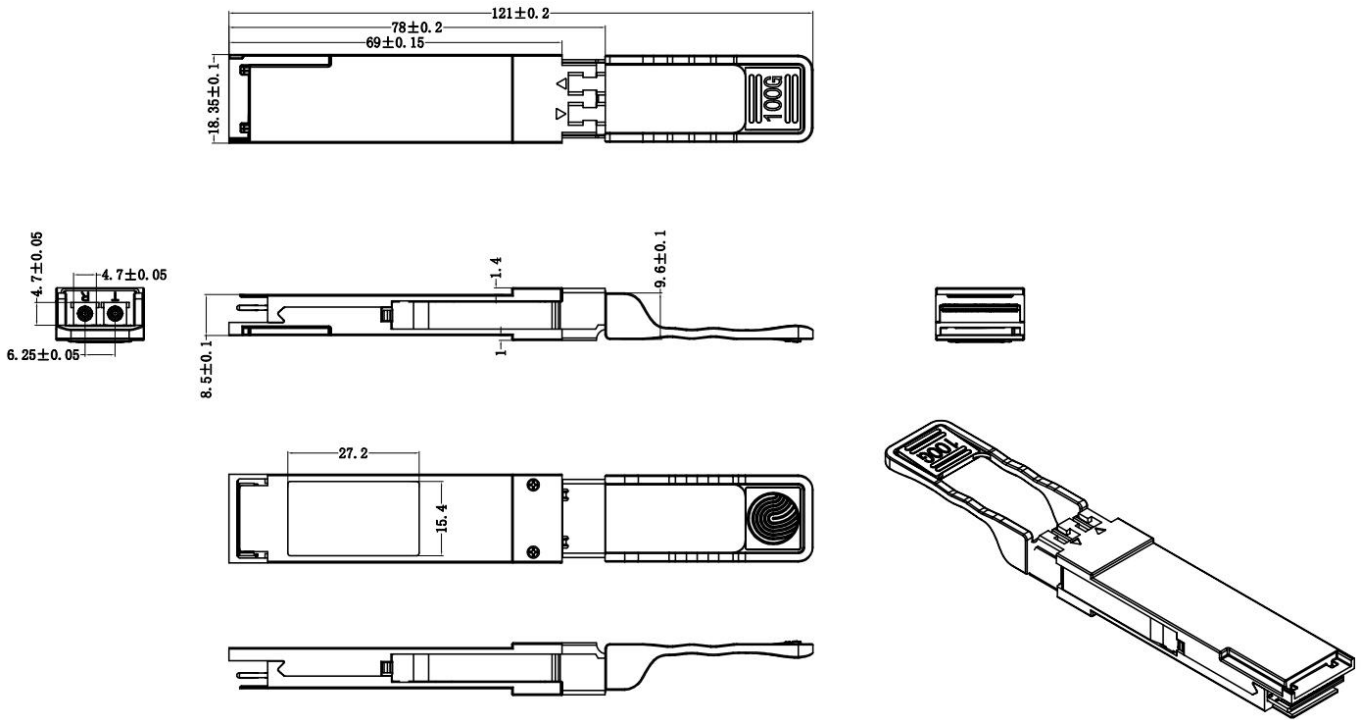

## Ordering information

Part Number	Product Description
QFP-LW31HG-A0DC	100Gbps QSFP28 ZR4, LC, 100km, 0°C~+70°C, with DDM

## For More Information

Tel: +86-755-23301665

E-mail : [sales@fibertoptech.com](mailto:sales@fibertoptech.com)

Web: <http://www.fibertoptech.com>